

ESPLOSO E LISTA RICAMBI

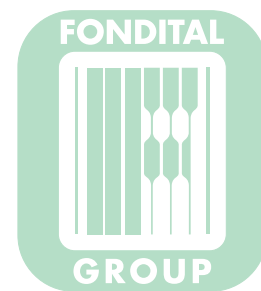

Chio BTFS 28

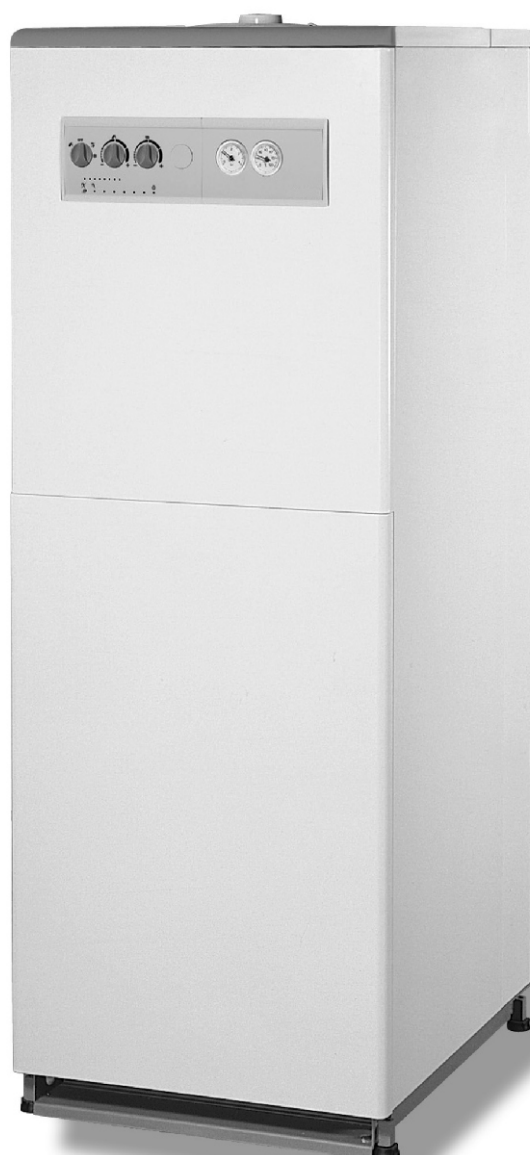

Lepus BTFS 28

Materiali pubblicati su www.piccinini.it con unica funzione di consultazione e destinato solo ai clienti Piccinini come supporto alla vendita.

Edizione 11/2004 - C 148-00

Di esclusiva proprietà dell'azienda che lo ha prodotto.

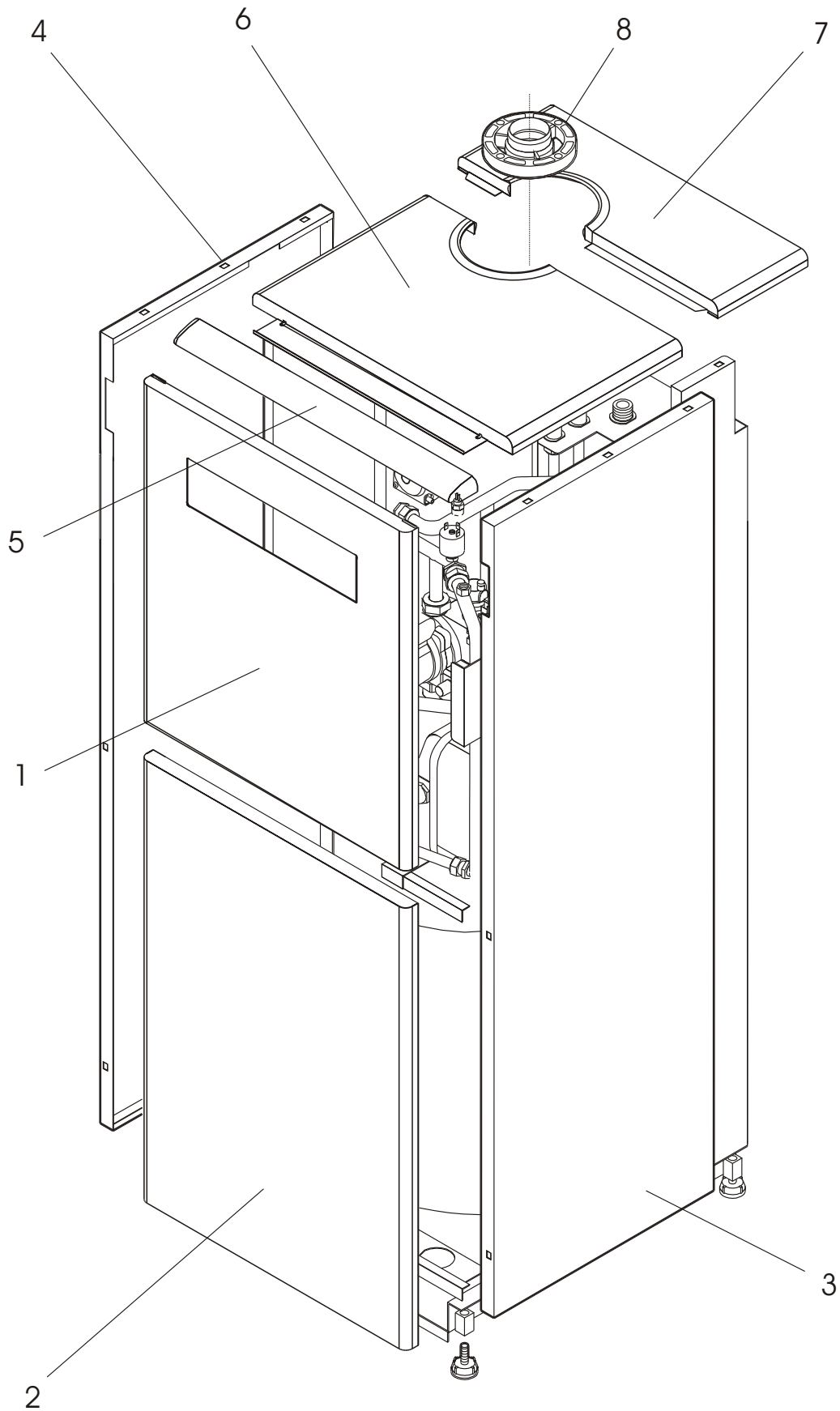

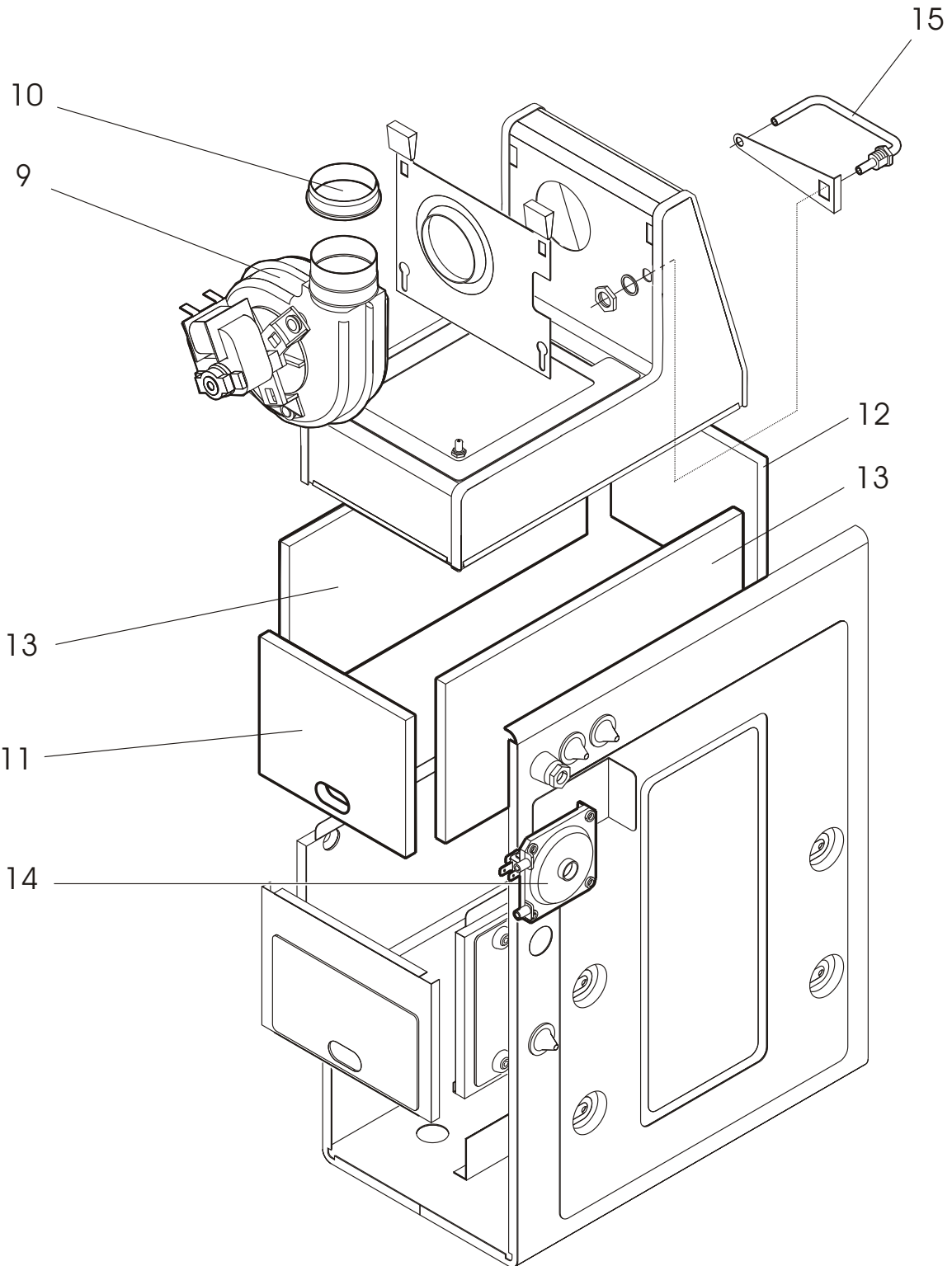

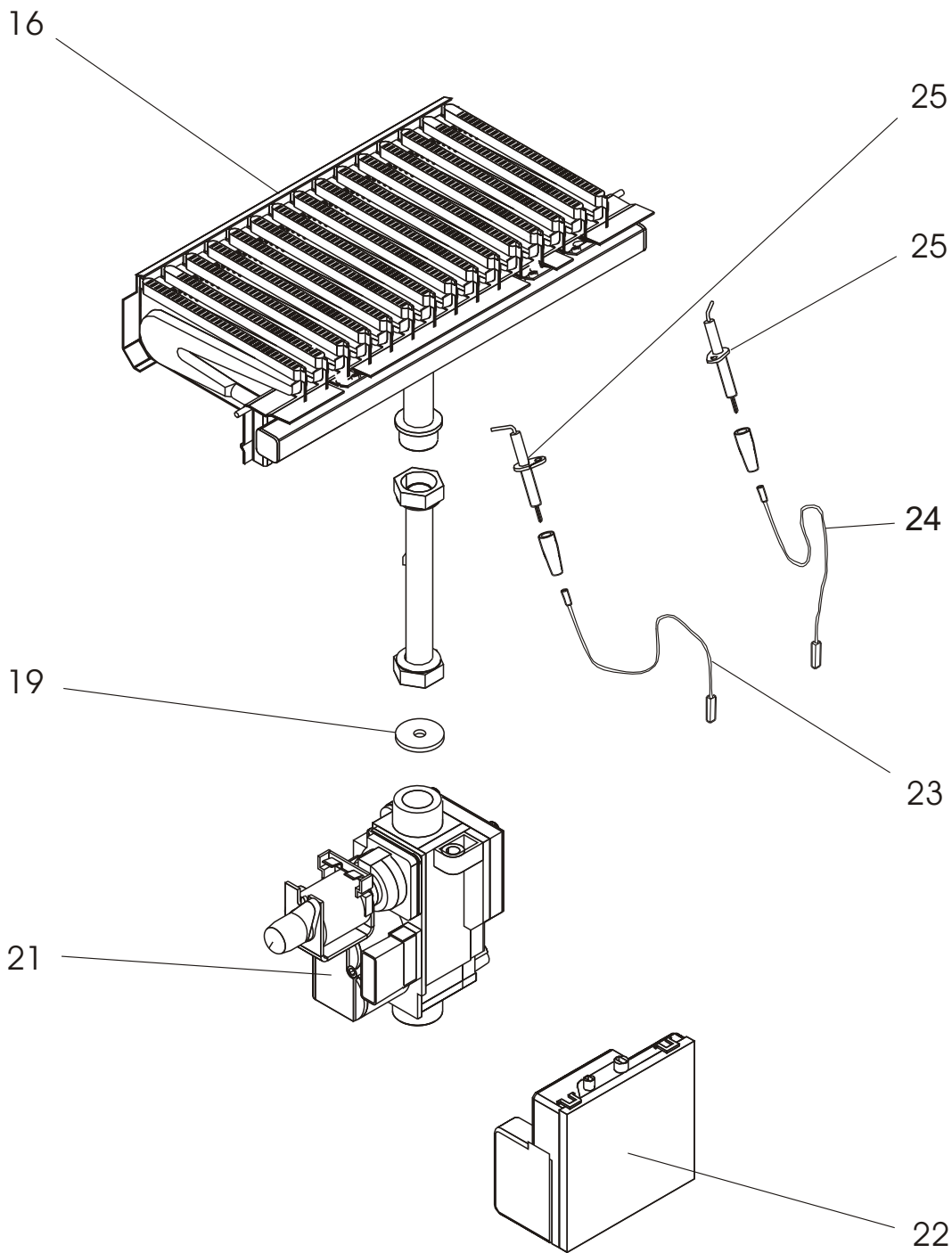

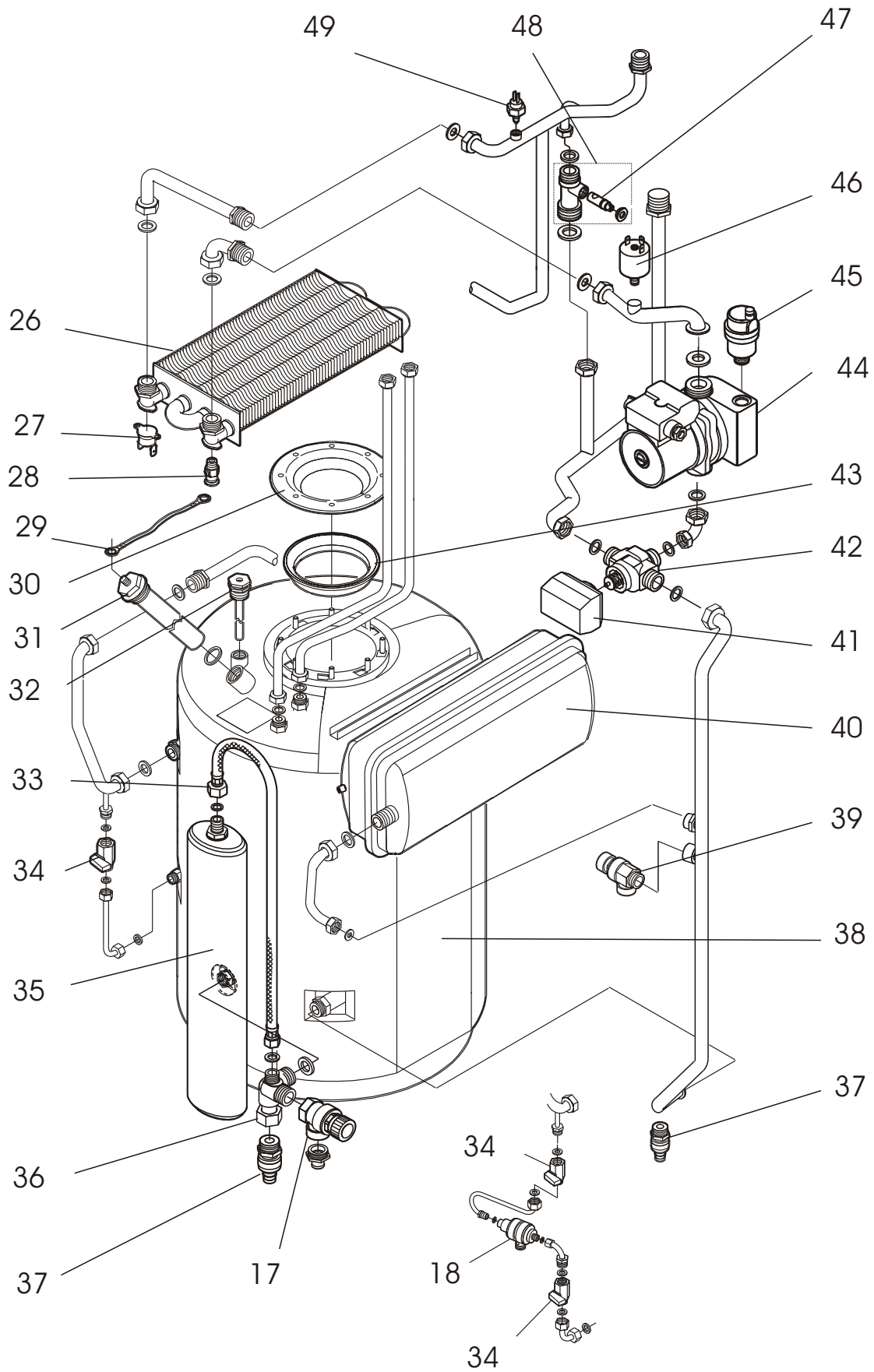

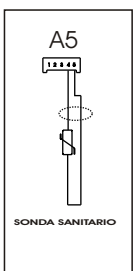
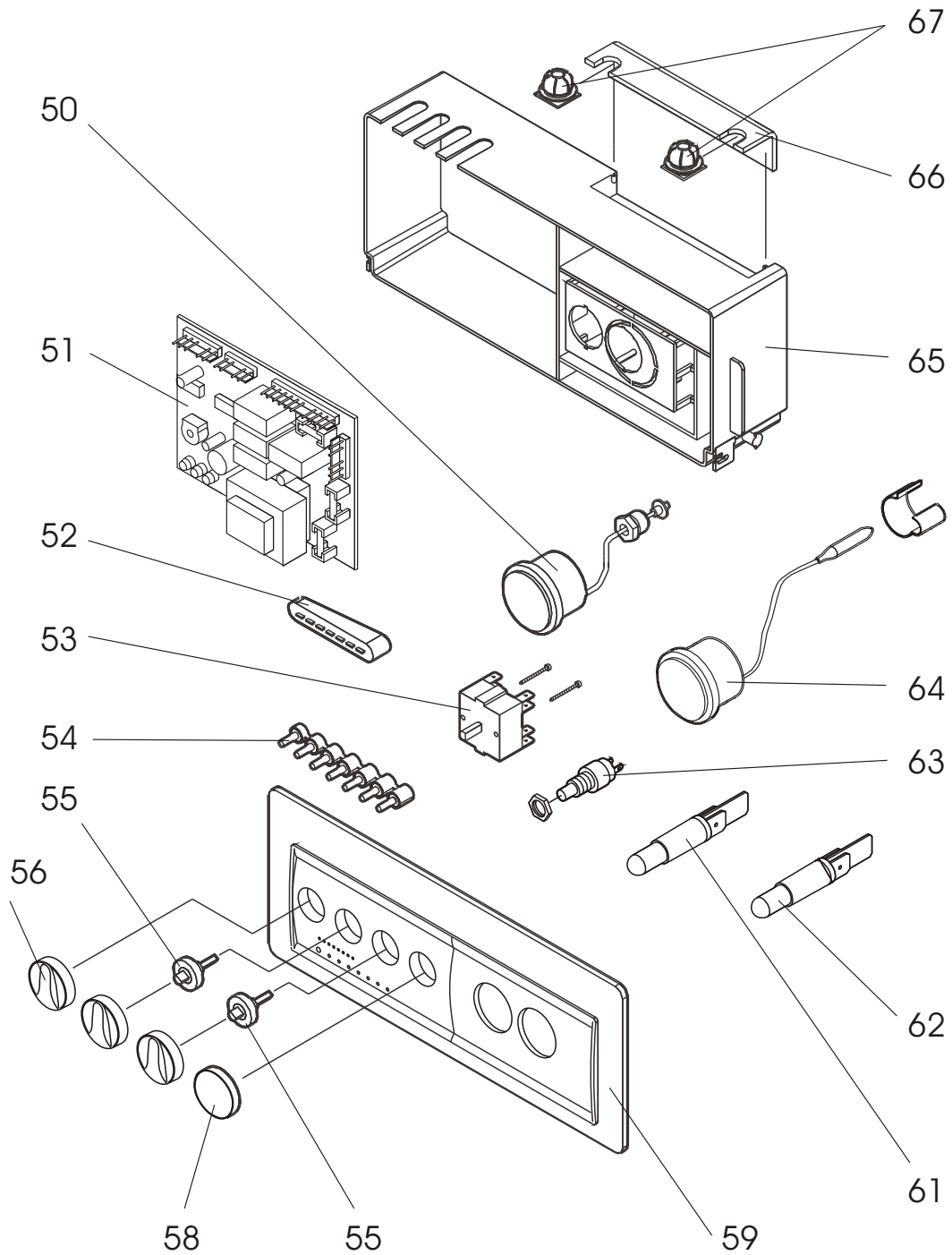

71

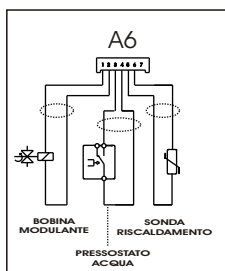

72

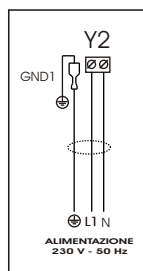

68

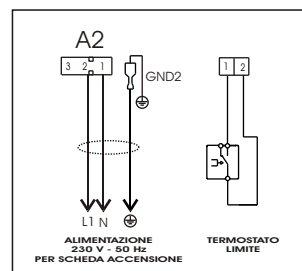

69

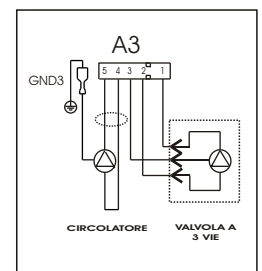

70

Riferimenti esploso Chio-Lepus BTFS 28

Esp	Codice	Pz	Descrizione	Description
1	6FROMASU00	1	FRONTALE MANTELLO SUPERIORE	UPPER CASING FRONT PANEL
2	6FROMAIN00	1	FRONTALE MANTELLO INFERIORE	LOWER CASING FRONT PANEL
3	6FIAMADE00	1	FIANCO MANTELLO DX	R-H CASING SIDE PANEL
4	6FIAMASI00	1	FIANCO MANTELLO SX	L-H SIDE CASING PANEL
5	6PROCOPA00	1	PROFILATO PLASTICA COPERCHIO ANT: MANTELLO	PLASTIC EDGE FOR FRONT CASING COVER
6	6COPEANT00	1	COPERCHIO ANTERIORE MANTELLO	CASING FRONT COVER
7	6COPEPOS00	1	COPERCHIO POSTERIORE MANTELLO	JACKET REAR COVER
8	6COLLCOM00	1	COLLARE DI COMPENSAZIONE	COMPENSATION COLLAR
9	6VENTILA04	1	VENTILATORE CHIO-LEPUS	CHIO LEPUS-FAN
10	6GUASIMV00	1	GUARNIZIONE SILICONE MANICOTTO VENTILATORE	FAN SLEEVE SILICON GASKET
11	6TERMANT02	1	TERMOISOLANTE ANTERIORE 178X145X12	FRONT HEAT INSULATION PANEL 178X145X12
12	6TERMP0S02	1	TERMOISOLANTE POSTERIORE 178X145X12	REAR HEAT INSULATION PANEL 178X145X12
13	6TERMLAT03	1	TERMOISOLANTE LATERALE 362X168X12	SIDE HEAT INSULATION PANEL 362X168X12
14	6PRESVEN00	1	PRESSOSTATO VENTILATORE	FAN PRESSURE SWITCH
15	6TUBSOVE00	1	TUBO SONDA VENTILATORE	FAN PROBE PIPE
16	6BRUCORM06	1	BRUCIATORE 15 RAMPE D 1,20 METANO	BURNER, 15 RAMPS Ø 1,20 METHANE
	6BRUCORG04	1	BRUCIATORE 15 RAMPE D 0,75 GPL	BURNER, 15 RAMPS Ø 0,75 GPL
	6BRUCORG05	1	BRUCIATORE 15 RAMPE D 1,40 GAS L (RUSSIA)	BURNER, 15 RAMPS Ø 1,40 GAS L (ONLY FOR RUSSIA)
17	6VALSIBA06	1	VALVOLA DI SICUREZZA 7 BAR	7-BAR SAFETY VALVE FOR CHIO LEPUS
18	6DISCONN00	1	DISCONNETTORE	CIRCUIT BREAKER
19	6DIAFRAM08	1	DIAFRAMMA Ø 6,8 MM (SOLO PER FR)	DIAPHRAGM Ø 6.8 MM (ONLY FOR FR) BTN 28+C181
	6DIAFRAM03	1	DIAFRAMMA Ø 6,3 MM (SOLO PER FR) BTFS 28	DIAPHRAGM Ø 6.3 MM (ONLY FOR FR) BTFS 28
21	6VALVGAS01	1	VALVOLA GAS PER ACCUMULO	STORAGE GAS VALVE
22	6SCHEACC00	1	SCHEDE ACCENSIONE ELETTRONICA TFS	ELECT. IGNITION BOARD FOR TFS
23	6CAVELAC00	1	CAVETTO ELETTRODO DI ACCENSIONE	IGNITION ELECTRODE CABLE
24	6CAVELRIO2	1	CAVETTO ELETTRODO DI RIVELAZIONE	DETECTION ELECTRODE CABLE
25	6CANDACR00	5	CANDELETTA ACCENSIONE O RIVELAZIONE	IGNITION OR DETECTION SPARK PLUG
26	6SCAMMON04	1	SCAMBIATORE MONOTERMICO	MONOTHERMAL HEAT EXCHANGER
27	6TERMSIC01	1	TERMOSTATO DI SICUREZZA 105° C	SAFETY THERMOSTAT 105° C
28	6VALVSFI01	1	VALVOLA DI SFIATO	AIR VALVE
29	6CAVMATE00	1	CAVETTO DI MASSA A TERRA L = 250 MM	EARTHING CABLE L = 250 MM
30	6FLANBOL00	1	FLANGIA BOLLITORE	TANK HEATER FLANGE
31	6ANODMGN00	1	ANODO DI MAGNESIO	MAGNESIUM ANODE
32	6GUAIPOR01	1	GUAINA PORTABULBO	BULB-HOLDER SHEATH
33	6TUBOFLE00	1	TUBO FLESSIBILE LUNG. 700	HOSE PIPE L= 700
34	6RUBISFE00	1	RUBINETTO A SFERA	BALL COCK
35	6VASOESP08	1	VASO D'ESPANSIONE 4 LITRI BASAMENTO	4 LITRE EXPANSION TANK FLOOR-STANDING BOILER
36	6GRUENFR00	1	GRUPPO ENTRATA FREDDA	COLD INLET UNIT
37	6RUBISCA00	1	RUBINETTO SCARICO BOLLITORE	TANK HEATER TAP
38	6BOLLITO00	1	BOLLITORE	TANK HEATER
39	6VALSIBA05	1	VALVOLA DI SICUREZZA 3 BAR	3-BAR SAFETY VALVE FOR CHIO LEPUS
40	6VASOESP09	1	VASO D'ESPANSIONE 10 LITRI BASAMENTO	10 LITRE EXPANSION TANK FLOOR-STANDING BOILER
41	6MOTVADE00	1	MOTORE VALVOLA DEVIATRICE	SWITCHING VALVE MOTOR
42	6CORVADE00	1	CORPO VALVOLA DEVIATRICE	SWITCHING VALVE BODY
43	6GUAFLE00	1	GUARNIZIONE FLANGIA BOLLITORE	WATER HEATER FLANGE GASKET
44	6CIRCOLA02	1	CIRCOLATORE SHUL 15/6	SHUL 15/6 CIRCULATING PUMP
45	6VALSFAU00	1	VALVOLA SFIATO AUTOMATICA DEGASATORE	AUTOMATIC DEGASSER AIR VALVE
46	6PRESMIN00	1	PRESSOSTATO DI MINIMA	MINIMUM PRESSURE SWITCH
47	6PERVALB00	1	PERNO VALVOLA BY-PASS	BY-PASS VALVE PIN
48	6VALVBYP00	1	VALVOLA BY-PASS	BY-PASS VALVE
49	6SENSORE00	1	SENSORE	SENSOR
50	6MANOMET00	1	MANOMETRO	PRESSURE GAUGE
51	6SCHEMOD02	1	SCHEDE DI MODULAZIONE NIAS/LIBRA	MODULATION BOARD FOR NIAS/LIBRA
52	6TRASLUC02	1	TRASPORTATORE DI LUCE TERMOMETRO PANNELLO	PANEL THERMOMETER LIGHT CARRIER
53	6COMESIN00	1	COMMUTATORE ESTATE-SPENTO-INVERNO	SUMMER-OFF-WINTER SELECTOR SWITCH
54	6TRASLUC01	1	TRASPORTATORE DI LUCE LED PANNELLO	PANEL LED LIGHT CARRIER
55	6ADATTMR00	5	ADATTATORE TRIMMER	TRIMMER ADAPTOR
56	6MANOTER00	5	MANOPOLA DI REGOLAZIONE	REGULATION KNOB
58	6TAPPMAN00	5	TAPPO MANOPOLA	KNOB CAP
59	6PANTAMP01	1	PANNELLO TAMPOGRAFATO NF	NOVA FLORIDA PRINTED PANEL
	6PANTAMP00	1	PANNELLO TAMPOGRAFATO FN	FONDITAL PRINTED PANEL
61	6LAMPROS00	1	LAMPADA ROSSA	RED LIGHT
62	6LEDVBQF00	1	LED VERDE BIPOLARE 40V FASTON	GREEN LIGHT, TWO-POLE 40V FASTON
63	6PULSRIA00	1	PULSANTE DI RIARMO	RESET BUTTON
64	6TERMOMT00	1	TERMOMETRO	THERMOMETER
65	6SCAPAIN00	1	SCATOLA PANNELLO INCASSO	FLUSH PANEL BOX
66	6COPMOSC00	1	COPERCHIO MORSETTIERE SCATOLA	TERMINAL BOARD BOX COVER
67	6PRESSCV00	5	PRESSACAVO ESTR.	CABLE GLAND
68	6CAVOALI00	1	CAVO DI ALIMENTAZIONE	SUPPLY CABLE
69	6COSTACO12	1	CO-STAMPATO CONN. A2	MOULDED-ON CONNECTOR A2
70	6COSTACO11	1	CO-STAMPATO CONN. A3	MOULDED-ON CONNECTOR A3
71	6COSTACO10	1	CO-STAMPATO CONN. A5	MOULDED-ON CONNECTOR A5
72	6COSTACO13	1	CO-STAMPATO CONN. A6	MOULDED-ON CONNECTOR A6

Materiale pubblicato su www.piccinini.it con unica funzione di consultazione e destinato solo ai clienti Piccinini come supporto alla vendita.

Edizione 11/2004 - C 148-00

Di esclusiva proprietà dell'azienda che lo ha prodotto.