

ESPLOSO RICAMBI CALDAIE DOMESTICHE

Modello

GENUS-EGIS PREMIUM EXT/IN

R8216212-05IT - Edizione 05 - 08/06/2010

3300262		GENUS PREMIUM IN 25 MET
3300372		GENUS PREMIUM SOLAR IN 25 MET
3300270		GENUS PREMIUM IN SYSTEM 12 FF MET
3300269		GENUS PREMIUM IN SYSTEM 25 FF MET
3300263		EGIS PREMIUM IN 25 MET
3300278		GENUS PREMIUM EXT 25 MET
Codice	Ind.	Modello	Date inizio	Data fine

Rifer. figura	Descrizione	Codice	Tipo							Data		
				GENUS P.		GENUS P. SOLAR		IN		EXT		
				25	25	12	25	25	25	da	a	
0100	BRUCIATORE											
0101	SCAMBIATORE 24KW	60000292		•	•	•	•	•				
	SCAMBIATORE 12KW	60001128				•						
0102	SPORTELLO COMPLETO	60000318		•	•	•	•	•				
0110	ELETTRODO D'ACCENSIONE	60000868		•	•	•	•	•				
0111	ELETTRODO DI IONIZZAZIONE	60000867		•	•	•	•	•				
0112	GUARNIZIONE D:85-66.5-2.5	61314753		•	•	•	•	•				
0114	SIFONE	60000987		•	•	•	•	•				
0120	MOLLA PANNELLO FRONTALE (KIT)	65107048		•	•	•	•	•				
0127	PANNELLO ANT. CAMERA STAGNA	65105678		•	•	•	•	•				
0133	DEGASATORE	60000994		•	•	•	•	•				
0134	GUARNIZIONE ELETTRODI	60000286		•	•	•	•	•				
0135	SERIE PANNELLI FIBRA CERAMICA	60000297		•	•	•	•	•				
0136	GUARNIZIONE PORTA	60000623		•	•	•	•	•				
0137	BRUCIATORE 24KW	60000288		•	•	•	•	•				
	BRUCIATORE 12-18KW	60000864				•						
0150	TUBO PVC D:19 LUNG:750	60000976		•	•	•	•	•				
0151	TUBO SCARICO CONDENSA	65107074		•	•	•	•	•				
0152	TUBO SIL. D: 8x1 LUNG : 0.15M	60001013		•	•	•	•	•				
0200	ESTRATTORE COMPLETO											
0202	RACCORDO BI-FLUSSO	60000523		•	•	•	•	•				
0203	GUARNIZIONE	60000317		•	•	•	•	•				
0205	GUARNIZIONE A LABBRO	60000316		•	•	•	•	•				
0213	TAPPO ANALISI FUMI + O-RING	65104295		•	•	•	•	•				
0220	GUARNIZIONE 80mm	60000315		•	•	•	•	•				
0300	CAMERA STAGNA											
0304	TAPPO RITORNO ARIA	65104249		•	•	•	•	•				
0305	GOMMINO INGRESSO CAVI	60000716		•	•	•	•	•				
0317	PANNELLO LATERALE DX	65107067		•	•	•	•	•				
0318	PANNELLO LATERALE SX	65107068		•	•	•	•	•				
0321	GUARNIZIONE ACQUA-GAS 3/8	573521		•	•	•	•	•				
0324	TUBO VASO ESPANSIONE	65107070		•	•	•	•	•				
0325	ANELLO OR D: 8.9-2.7	61009834-14		•	•	•	•	•				
0327	VASO ESPANSIONE UNIFICATO 7 LITRI	65101719		•	•	•	•	•				
0328	IDROMETRO	65104234		•	•	•	•	•				
0337	SUPPORTO GRUPPO IDRAULICO	65104311		•	•	•	•	•				
0362	MAGNETE	65104670		•	•	•	•	•				
0363	SUPPORTO VASO ESPANSIONE	65107069		•	•	•	•	•				
0365	SUPPORTO IDROMETRO	65107076		•	•	•	•	•				
0400	GRUPPO GAS											
0401	VALVOLA GAS	60000537		•	•	•	•	•				
0402	CONDOTTO	60000290		•	•	•	•	•				
0404	VENTURI D: 17MM	60000536		•	•	•	•	•				
	VENTURI D: 14MM	65105894				•						
0407	VENTILATORE	60000622		•	•	•	•	•				
0410	GUARNIZIONE	61306072		•	•	•	•	•				
0412	SILENZIATORE	60000539		•	•	•	•	•				
0419	TUBO GAS	65107075		•	•	•	•	•				
0420	DIAFRAMMA GAS D: 4.50	60000633				•						
0427	GUARNI. PIANA D: 24-18.2-1.5	60022835-01		•	•	•	•	•				
0480	ANELLO OR D: 17.76-1.78	61308092				•	•					

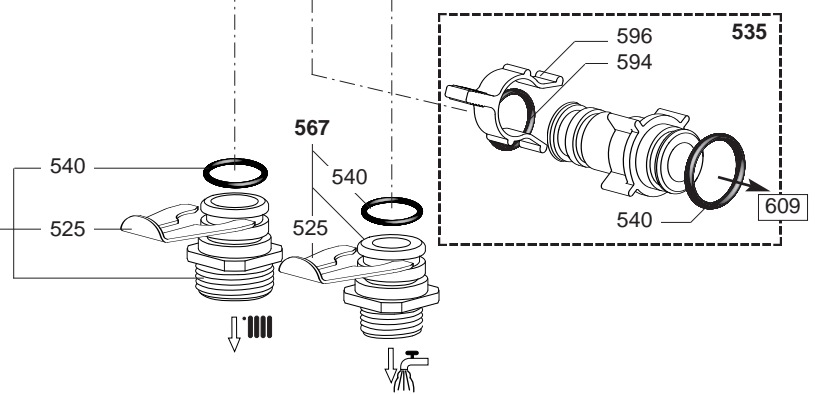
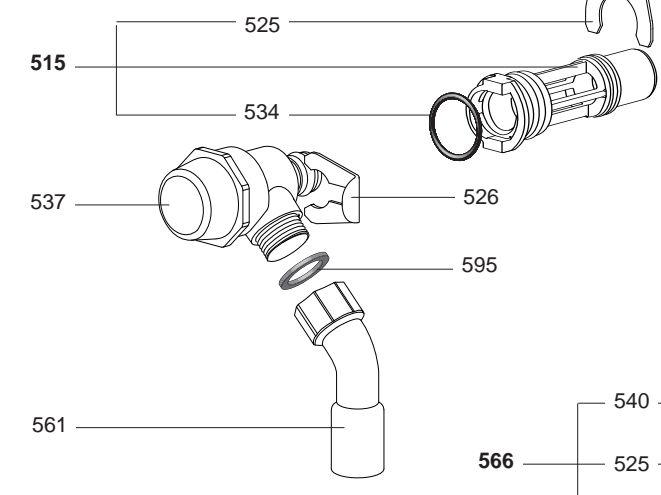
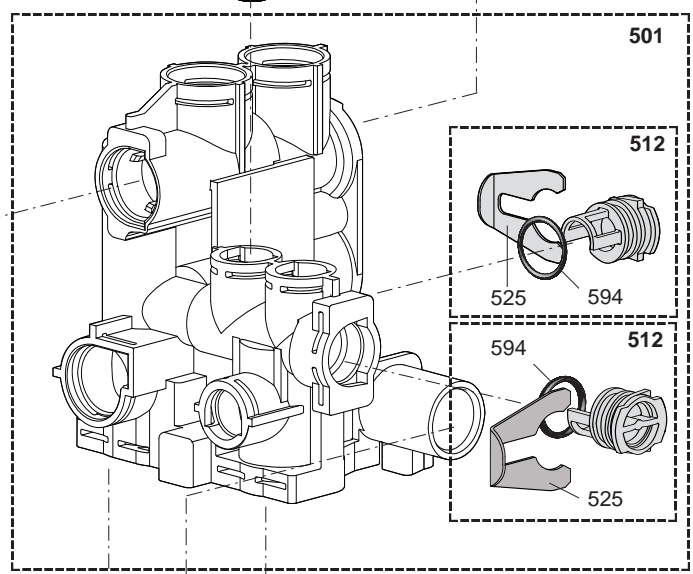
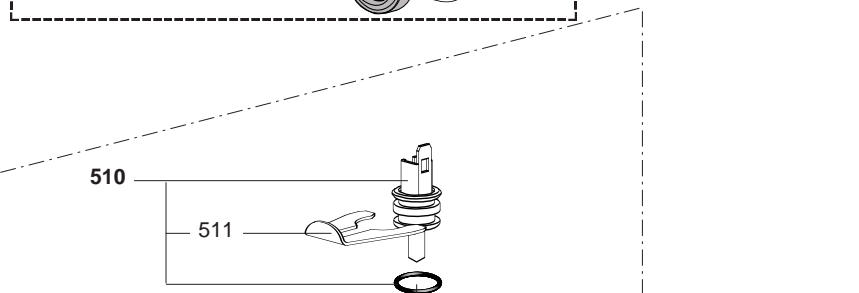
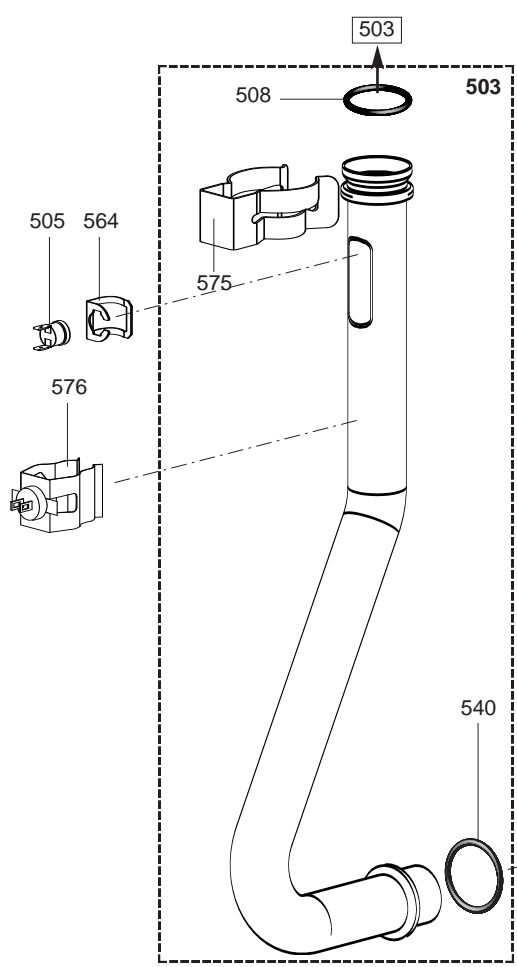
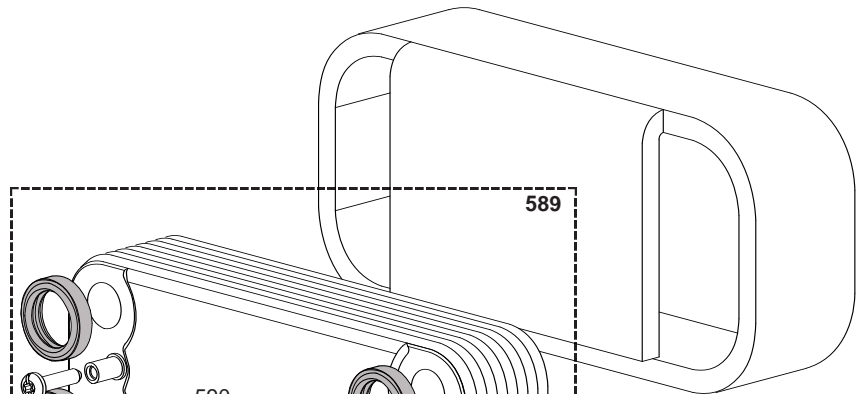
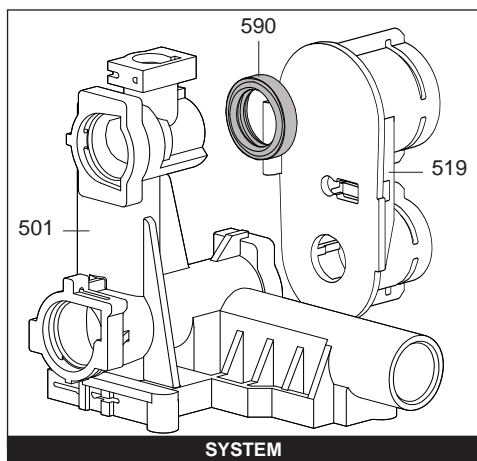

Rifer. figura	Descrizione	Codice	Tipo							Data	
				GENUS P.		GENUS P. SOLAR		IN		da	a
				25	25	12	25	25	25		
0500	PARTE MANDATA										
0501	GRUPPO MANDATA	65104312		•	•			•	•		
	GRUPPO MANDATA	65105091				•	•				
0503	TUBO MANDATA RISCALDAMENTO	60000534				•	•	•			
	TUBO MANDATA	65107072		•	•				•		
0505	SICUREZZA TERMICA 100Â°C	61010572		•	•	•	•	•	•		
0508	O-RING 3,53X17,04	65104262		•	•	•	•	•	•		
0510	SONDA NTC	65104338		•	•				•		
0511	CLIP	65104339		•	•				•	•	
0512	TAPPO	65104445		•	•	•	•	•	•		
0515	BY-PASS	65104336		•	•	•	•	•	•		
0519	INTERFACCIA 'System'	65105181				•	•				
0525	CLIP D=18	65104259		•	•	•	•	•	•		
0526	CLIP D:10	65104260		•	•	•	•	•	•		
0534	O - RING 15,88X2,62	65104337		•	•	•	•	•	•		
0535	TUBO BY-PASS	65104340		•	•	•	•	•	•		
0537	VALVOLA SICUREZZA 3 BAR	61312668		•	•	•	•	•	•		
0540	ANELLO OR D: 17.86-2.62	61308091		•	•	•	•	•	•		
0561	TUBO VALVOLA SICUREZZA	65104447		•	•	•	•	•	•		
0564	CLIP	61010050		•	•	•	•	•	•		
0566	RACCORDO 3/4	65104326		•	•	•	•		•		
0567	RACCORDO 1/2	65104327		•	•				•		
0575	CLIP	60000309		•	•	•	•	•	•		
0576	SONDA NTC T335D + CLIPS 18	990686		•	•	•	•	•	•		
0584	ANELLO OR D: 11.91-2.62	60000850							•		
0589	SCAMBIATORE SANITARIO	65104333		•	•				•	•	
0590	GUARNI. AUTO-SIGILLANTE	61002249		•	•				•	•	
0594	O - RING 15,54X2,62	65104325		•	•	•	•	•	•		
0595	GUARNI. PIANA D: 13.9-10.4-1.5	60061853-02		•	•	•	•	•	•		
0596	CLIP TUBO BY-PASS	65104700		•	•	•	•		•		

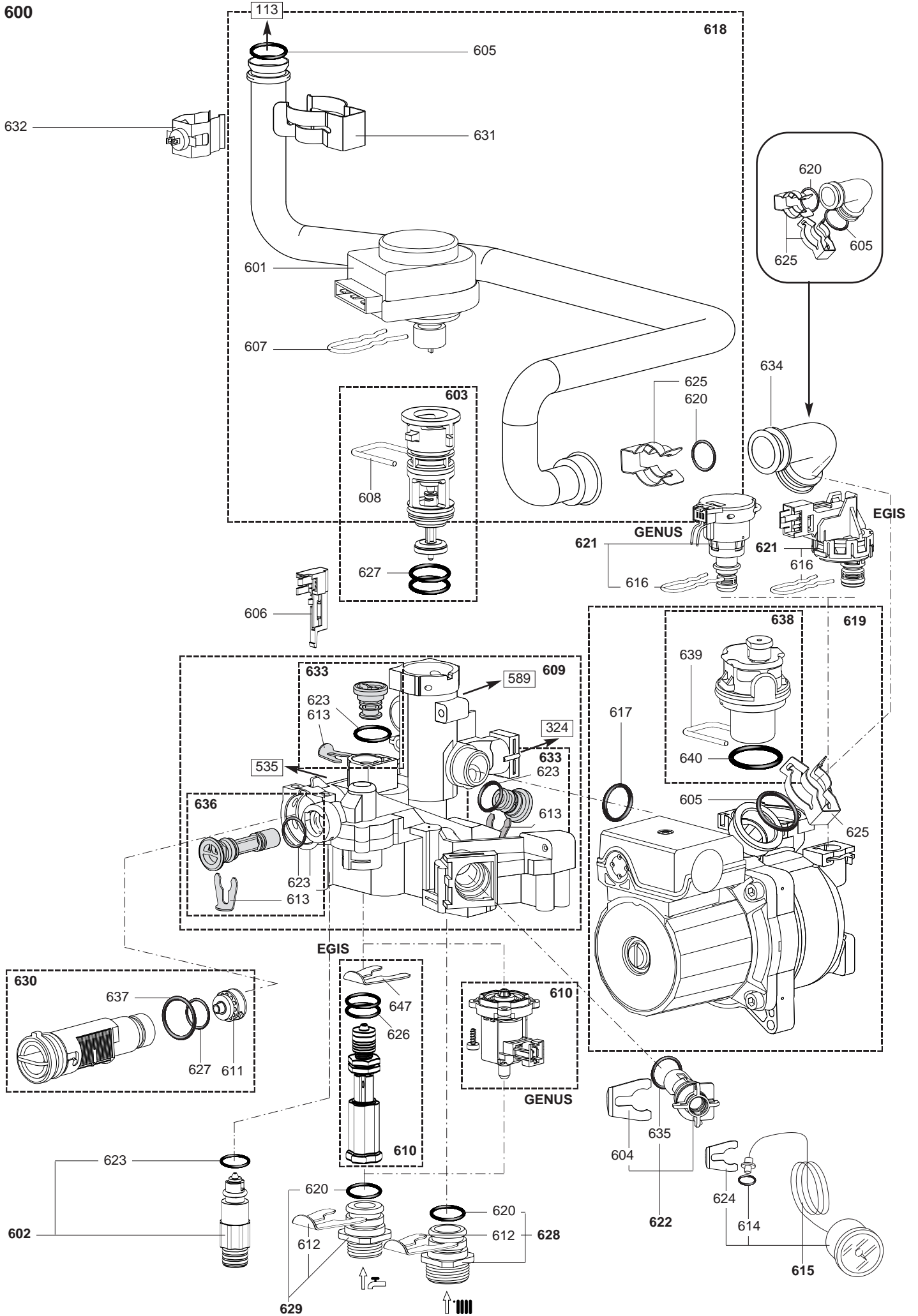

Rifer. figura	Descrizione	Codice	Tipo							Data	
				GENUS P.		GENUS P. SOLAR		IN		da	a
				25	25	12	25	25	25		
0600	PARTE RITORNO										
0601	MOTORE DI VALVOLA A 3 VIE	61302483		•	•		•	•			
0602	KIT SPURGO	60001385		•	•	•	•	•			
0603	OTTURATORE VALVOLA 3 VIE	65104314		•	•		•	•			
	TAPPO	65105093				•	•				
0604	CLIP	65104331		•	•	•	•	•			
0605	O-RING 3,53X17,04	65104262		•	•	•	•	•			
0606	SENSORE REED	65104323		•	•		•	•			
0607	CLIP	65104332		•	•		•	•			
0608	CLIP	65104316		•	•	•	•	•			
0609	GRUPPO RITORNO	65104335						•			
	GRUPPO RITORNO	65105322		•	•	•	•	•			
0610	RUBINETTO DI RIEMPIMENTO	65104324						•			
	RUBINETTO DI RIEMPIMENTO AUTO.	65104669		•	•	•	•	•			
0611	LIMITATORI DI PORTATA (KIT)	65104318		•	•	•	•	•			
0612	CLIP D=18	65104259		•	•	•	•	•			
0613	CLIP D:10	65104260		•	•		•	•			
0614	ANELLO OR D: 5.7-1.9	61009834-10		•	•	•	•	•			
0615	IDROMETRO	65104234		•	•		•	•			
0616	CLIP	65104322		•	•	•	•	•			
0617	O - RING 21,89X2,62	65104320		•	•	•	•	•			
0618	TUBO RITORNO RISCALDAMENTO	60000528					•	•			
	TUBO RITORNO	65107073		•	•			•			
	TUBO RITORNO	65107152				•					
0619	CIRCOLATORE 5M 1V	60000876						•			
	CIRCOLATORE 5M 2V	65104319		•	•	•	•	•			
0620	ANELLO OR D: 17.86-2.62	61308091		•	•	•	•	•			
0621	PRESSOSTATO PROPORZIONALE	65104321		•	•	•	•	•			
	PRESSOSTATO DI MINIMA	65105090						•			
0622	FILTRO ACQUA	60001372		•	•	•	•	•			
0623	O - RING 9,19X2,62	65104313		•	•	•	•	•			
0624	CLIP	65100680		•	•	•	•	•			
0625	CLIP	61307589		•	•	•	•	•			
0627	O - RING 23,47X2,62	65104315		•	•	•	•	•			
0628	RACCORDO 3/4	65104326				•	•				
0629	RACCORDO 1/2	65104327				•	•				
0630	FLUSSOSTATO SANITARIO	65104317		•	•			•	•		
	TAPPO OTTURATORE SANITARIO	65105179				•	•				
0631	CLIP	60000309		•	•	•	•	•			
0632	SONDA NTC T335D + CLIPS 18	990686		•	•	•	•	•			
0633	TAPPO	65104377		•	•	•	•	•			
0634	RACCORDO (POMPA - TUBO)	65107071		•	•	•	•	•			
0635	O - RING 15,54X2,62	65104325		•	•	•	•	•			
0636	CARTUCCIA VALVOLA RITEGNO	65105323		•	•	•	•	•			
0637	O-RING 17,17X1,78	65104303				•	•	•			
	O-RING 16,5X1,6	65105180		•	•			•			
0638	VALVOLA SFOGO ARIA + O-RING	65104703		•	•	•	•	•			
0639	FORCHETTA ATTACCO RAPIDO	65104704		•	•	•	•	•			
0640	O-RING	65104705		•	•	•	•	•			
0641	GUARNIZIONE SCAMBIATORE	65104334				•	•				
0647	CLIP	65104339						•			

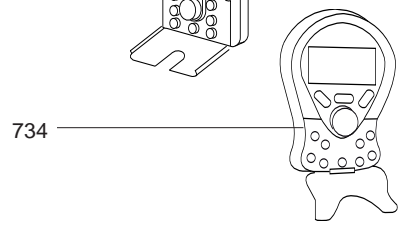
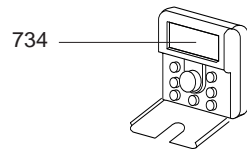
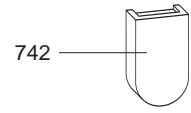
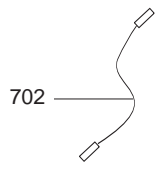
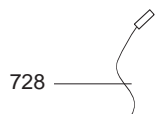
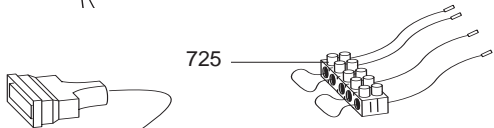
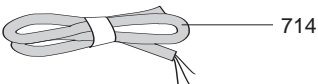
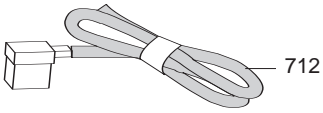
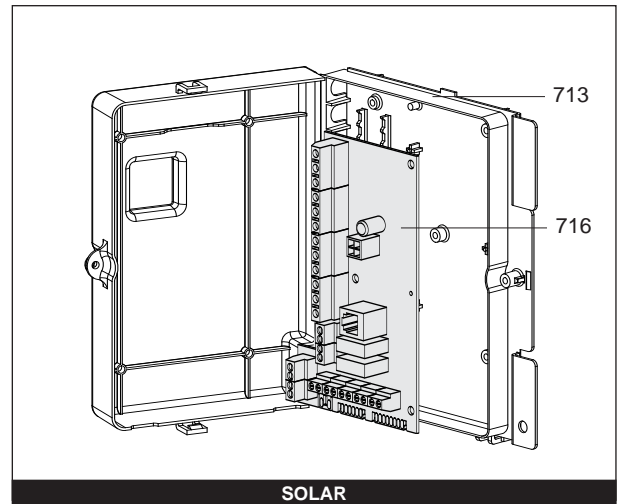
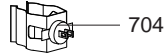
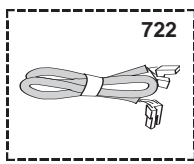
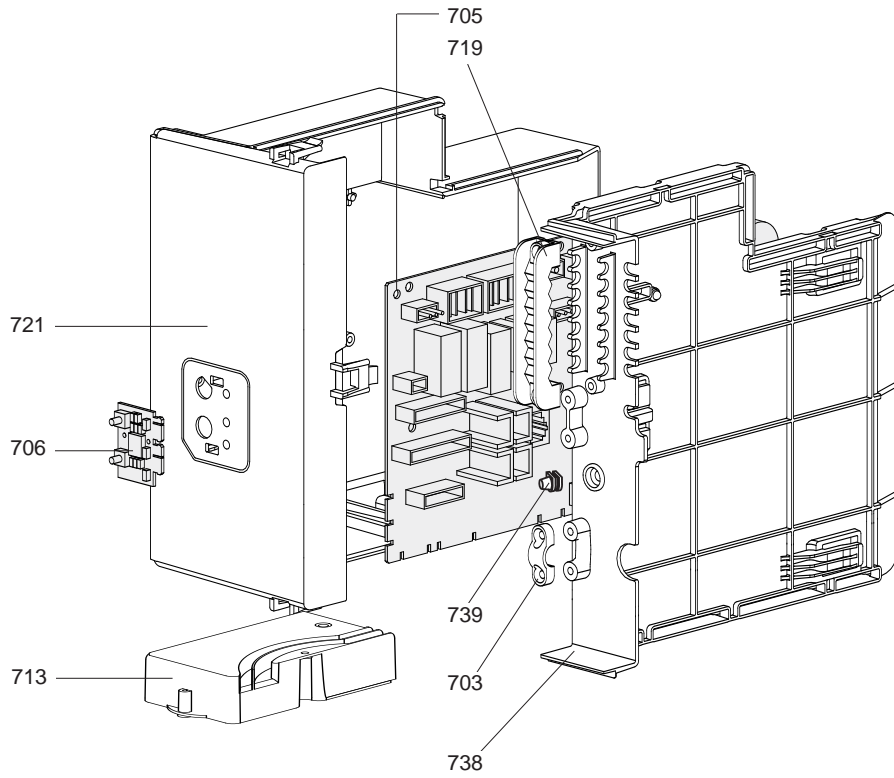

Rifer. figura	Descrizione	Codice	Tipo							Data	
				GENUS P.		GENUS P. SOLAR		IN		da	a
				25	25	12	25	25	25		
0700	SCATOLA ELETTRICA										
0702	CAVO TERRA CIRCOLATORE	65107066		•	•	•	•	•			
0703	FERMACAVO	571562		•	•	•	•	•			
0705	SCHEDA PRINCIPALE	65109138-02		•	•	•	•	•			
0706	SCHEDA DISPLAY	65107057		•	•	•	•	•			
0707	CABLAGGIO DISPLAY	65107065	/ CN02	•	•	•	•	•			
	CABLAGGIO DISPLAY	65107600	/ CN02					•			
0708	TRASFORMATORE AC	61002105-20		•	•	•	•	•			
0711	CABLAGGIO VALVOLA A 3 VIE	65104523	/ CN09	•	•			•	•		
0712	CABLAGGIO POMPA 1V	65107599						•			
	CABLAGGIO POMPA 2V	65104520	/ CN10	•	•	•	•		•		
0713	SCATOLA RACCORDO	60001252		•		•	•	•	•		
	SCATOLA RACCORDO	60001585			•						
0714	CABLAGGIO ALIMENTAZIONE 240V	60001146	/ CN20	•	•	•	•	•	•		
0716	SCHEDA SOLAR-IN	60001588			•						
0719	PRESSACAVO	65103377		•	•	•	•	•	•		
0721	SCATOLA SCHEDA	65107058		•	•	•	•	•	•		
0722	CABLAGGIO TRASFORMAT. ACC. - VALVOLA GAS	60000543	/ CN03	•	•	•	•	•	•		
	CABL. NTC - SICURI. TERM. - RIVEL. PRES.	60000742	/ CN04			•	•				
	CABL. NTC - RIVEL. PRES. - VALVOLA GAS	60000840	/ CN04	•	•			•	•		
	CABLAGGIO VALVOLA RIEMPIMENTO	65104525	/ CN12	•	•	•	•		•		
	CABLAGGIO FLUSSOSTATO	60000813	/ CN14	•	•	•	•	•	•		
	CABLAGGIO NTC - NTC SCAMB. - VENTILATORE	60001234	/ CN22		•						
	CABLAGGIO 6p CLIP-IN E-BUS	60001586	/ CN18		•						
	CABLAGGIO PROTETTORE SCAMBIATORE	65107063	/ CN22	•	•	•	•	•	•		
	CABLAGGIO 8p CLIP-IN E-BUS	60001587	/ CN24		•						
0725	CABLAGGIO TERMOSTATO AMBIENTE	65104524	/ CN25	•	•	•	•	•	•		
0728	CABLAGGIO ELETTRODO DI IONIZZAZIONE	60000567	/ CN05	•	•	•	•	•	•		
0734	CONTROLLO REMOTO	65105167		•	•	•	•		•		
	CONTROLLO REMOTO	65107607							•		
0738	COPERCHIO SCATOLA SCHEDA	65107059		•	•	•	•	•	•		
0739	PASSACAVO CHIUSO	569720		•	•	•	•	•	•		
0742	SONDA ESTERNA	65109110		•	•	•	•	•	•		

800

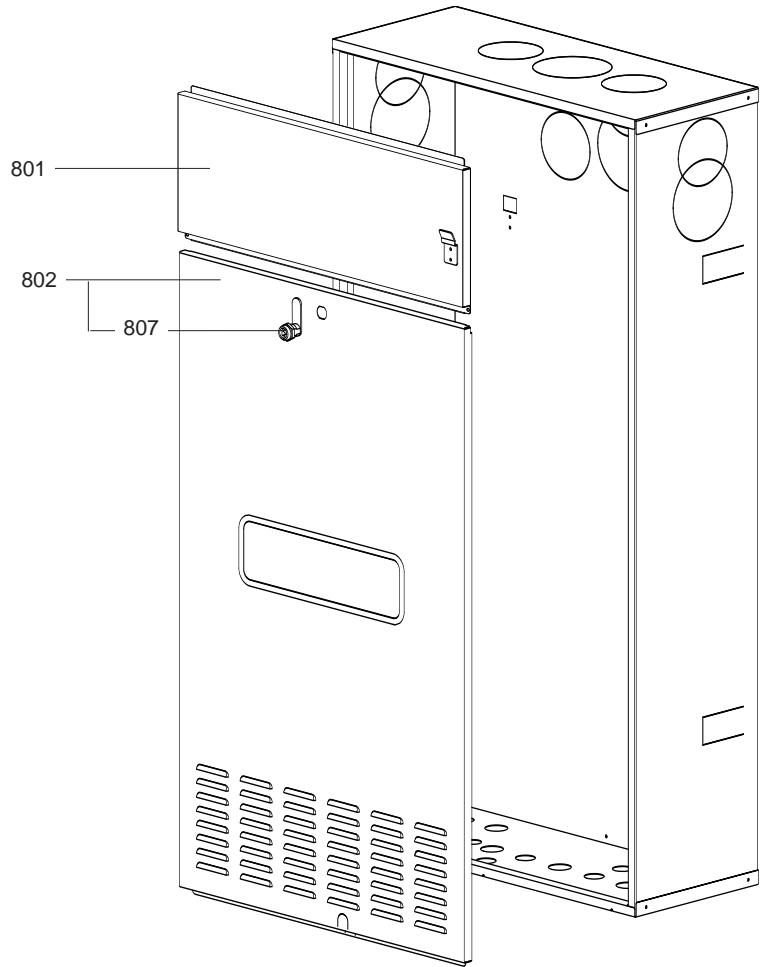
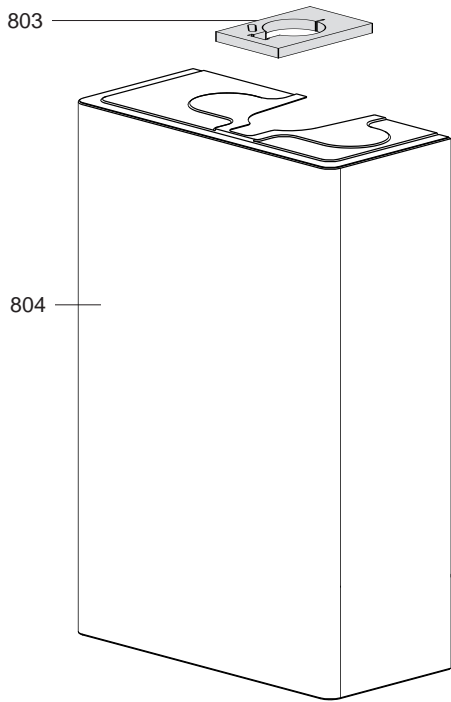

900

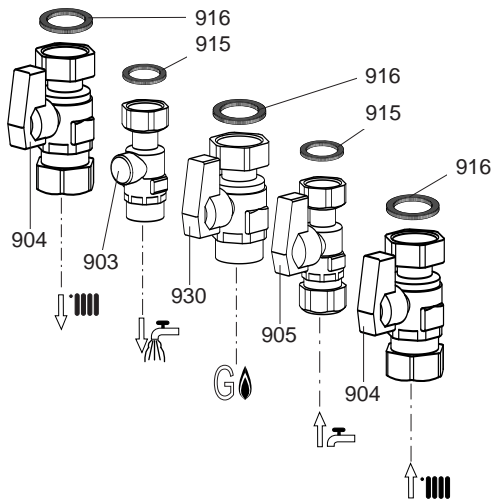

900

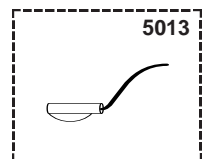
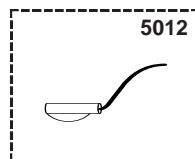
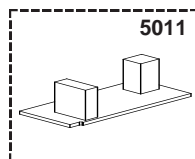
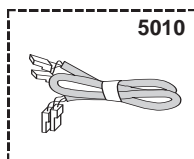
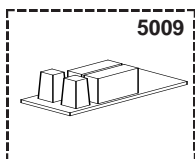
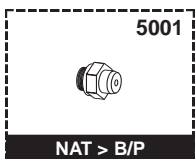

Rifer. figura	Descrizione	Codice	Tipo							Data	
				GENUS P.		IN		EXT		da	a
				25	25	12	25	25	25		
0800	COMPONENTI PER L'INSTALLAZIONE										
0801	PANNELLO FRONTALE SUPERIORE PRETR.TO	65107080		●		●	●	●			
0802	PANNELLO FRONTALE INFERIORE	65107081		●		●	●	●			
0803	GUARNIZIONE COLLARE	65107258							●		
0804	MANTELLO	65107256							●		
0807	CHIUSURA	65107082		●		●	●	●			
0900	PLACCA RAME RUBINETTERIA										
0904	RUBINETTO 3/4	65100255		●		●	●	●	●		
0905	RUBINETTO 1/2	65100256		●		●	●	●	●		
0915	GUARNIZIONE ACQUA-GAS 1/2	573528		●		●	●	●	●		
0916	GUARNIZIONE ACQUA-GAS 3/4	573520		●		●	●	●	●		
0930	RUBINETTO 3/4 GAS	65100257		●		●	●	●	●		
5000	OPZIONI										
5001	TRASFORMAZIONE GPL	60000752	LG	●	●		●	●	●		
	TRASFORMAZIONE GPL	60001126	LG			●					
5009	SCHEDA CLIP-IN HI-LO ZONE	65106892		●	●	●	●	●	●		
5010	CABLAGGIO CLIP-IN COMUNICAZIONE	65106893	/ CN24	●	●	●	●	●	●		
5011	SCHEDA CLIP-IN SOLAR	65107038		●		●	●	●	●		
5012	SENSORE NTC (COLLETTORE SOLARE)	65107144		●	●	●	●	●	●		
5013	SENSORE NTC (BOLLITORE SOLARE)	65107146		●	●	●	●	●	●		

ELENCO ABBREVIAZIONI UTILIZZATE

EC	: Acqua calda.
EF	: Acqua fredda.
C	: Resistenza ceramica (Riscaldamento normale).
Ca	: resistenza ceramica (Riscaldamento accelerato).
TP	: Resistenza immersa.
1F	: Con rubinetteria.
2F	: Senza rubinetteria.
3F	: con rubinetteria e uscita complementare.
AMI	: Con miscelatore integrato.
SMI	: Senza miscelatore integrato.
PUISS	: Natura dell'apparecchio.
PN	: Apparecchio a pressione normale.
BP	: Apparecchio a bassa pressione.
PV	: Apparecchio a potenza variabile.
PF	: Apparecchio a potenza stabile.

TARGA MATRICOLA

NUMERO DI SERIE

Es: 0537095 XX 2 04 070 00315

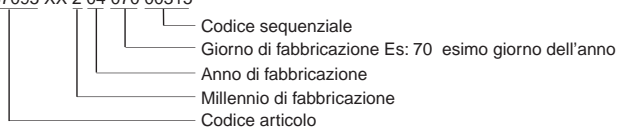

I dati presenti sulla tariffa e le documentazioni commerciali o tecniche, gli schemi e altre informazioni sono dati a titolo indicativo e validi per un certo periodo. Il COSTRUTTORE si riserva la facoltà di modificare la presentazione, la forma, la dimensione, la concezione o la materia dei suoi prodotti.