



ARISTON

SPARE PARTS EXPLODED VIEW GAS-WALL CONDENSING BOILERS

Model

GENUS - CLAS PREMIUM EVO IN/EXT

R8203406-04 - 11/07/2016

1	3300403	GENUS PREMIUM EVO IN 25	02-2014	08-2015
1	3300736	GENUS PREMIUM EVO IN 25 EU	01-2015	-
2	3300607	GENUS PREMIUM EVO IN SYTEM 25	02-2014	08-2015
2	3300737	GENUS PREMIUM EVO IN SYTEM 25 EU	01-2015	-
3	3300416	GENUS PREMIUM EVO EXT 25	02-2014	08-2015
3	3300735	GENUS PREMIUM EVO EXT 25 EU	01-2015	-
4	3300768	CLAS PREMIUM EVO IN 25 EU		
5	3300762	CLAS PREMIUM EVO EXT 25 EU		

Col	Reference	Model type	Begin	End
-----	-----------	------------	-------	-----

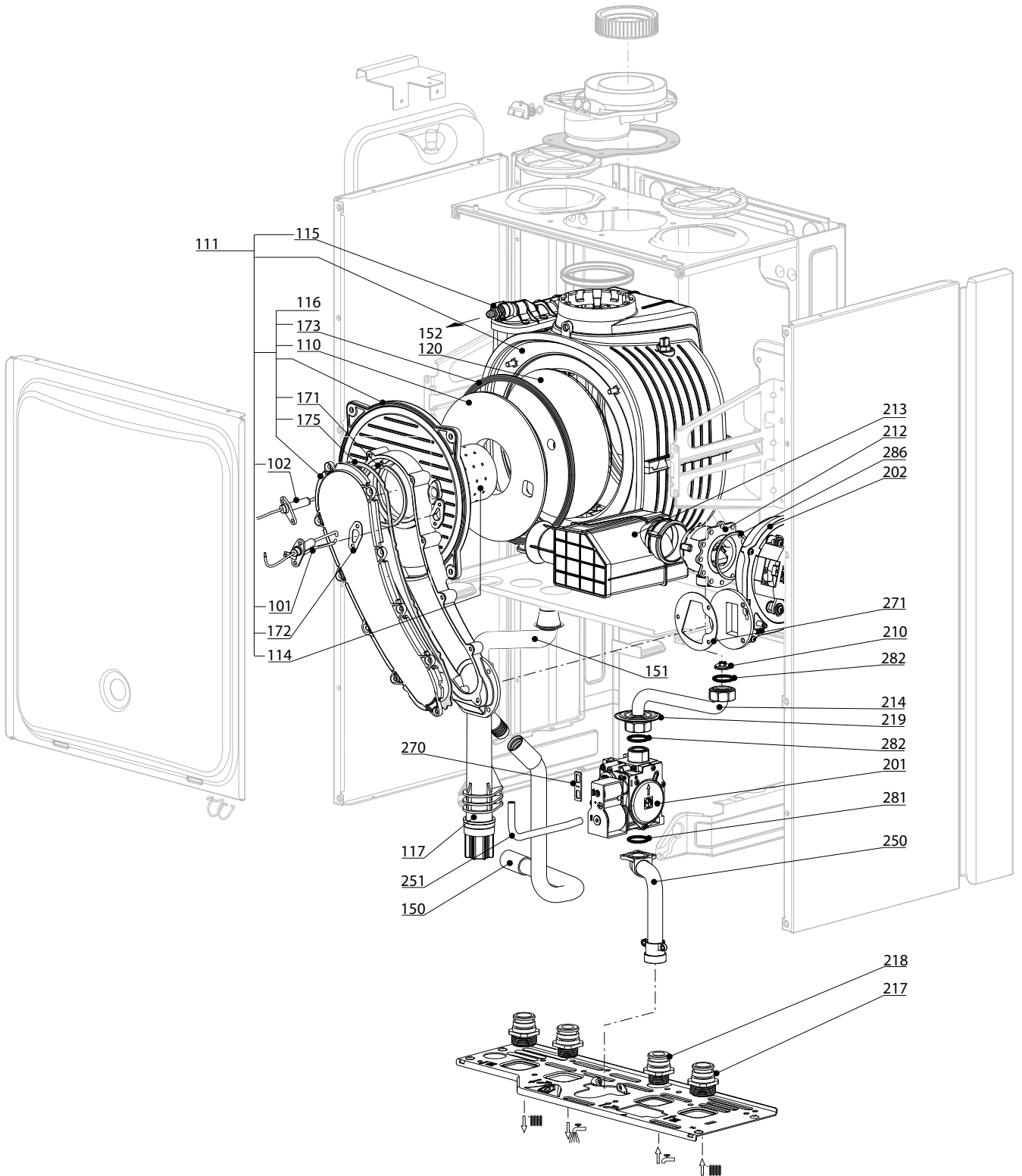

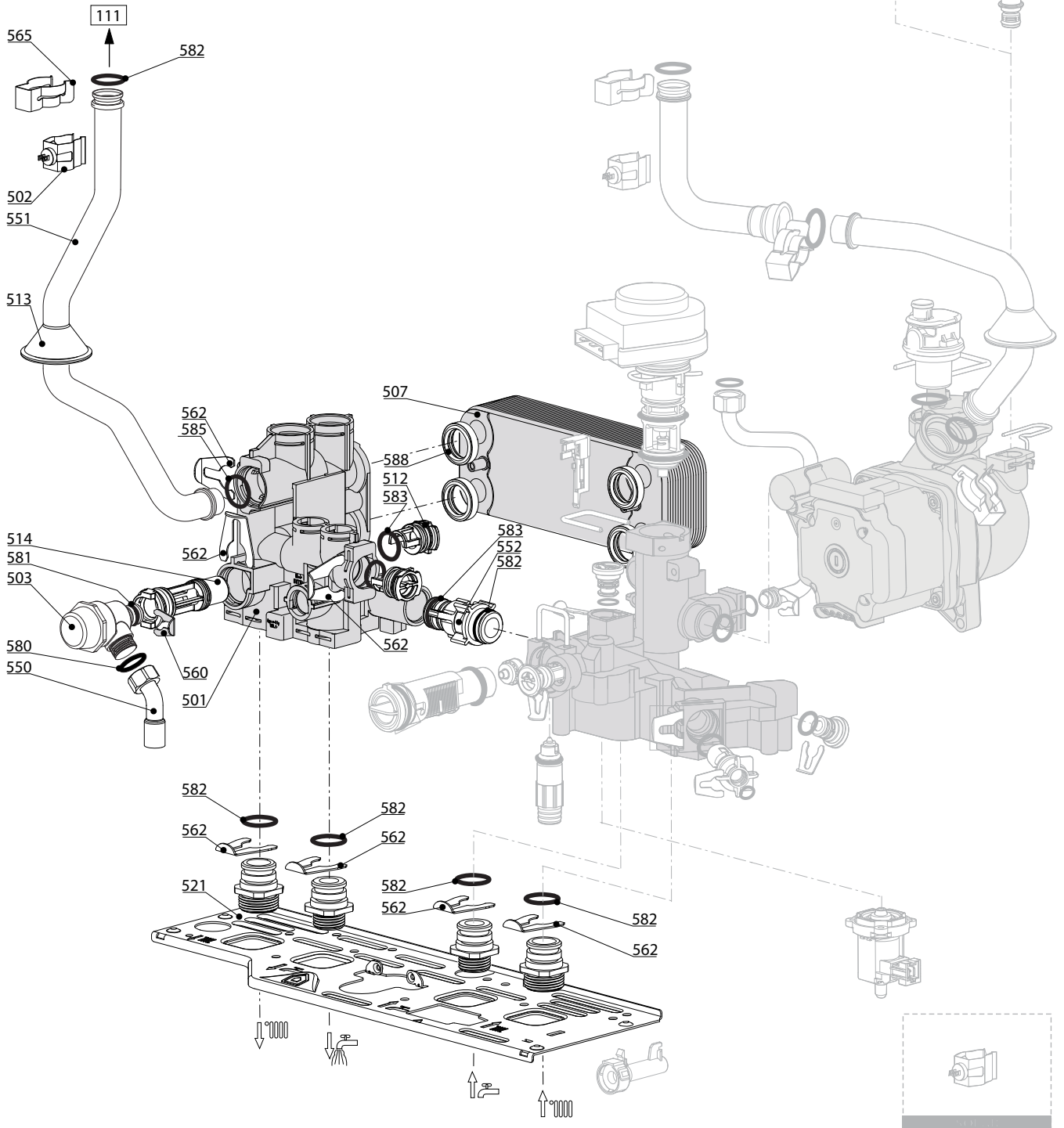
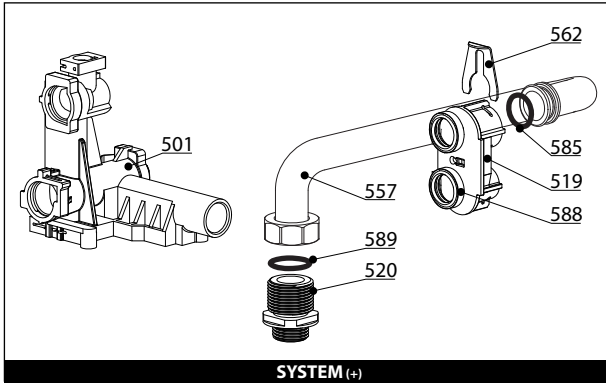

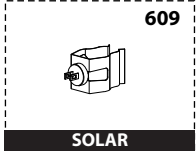
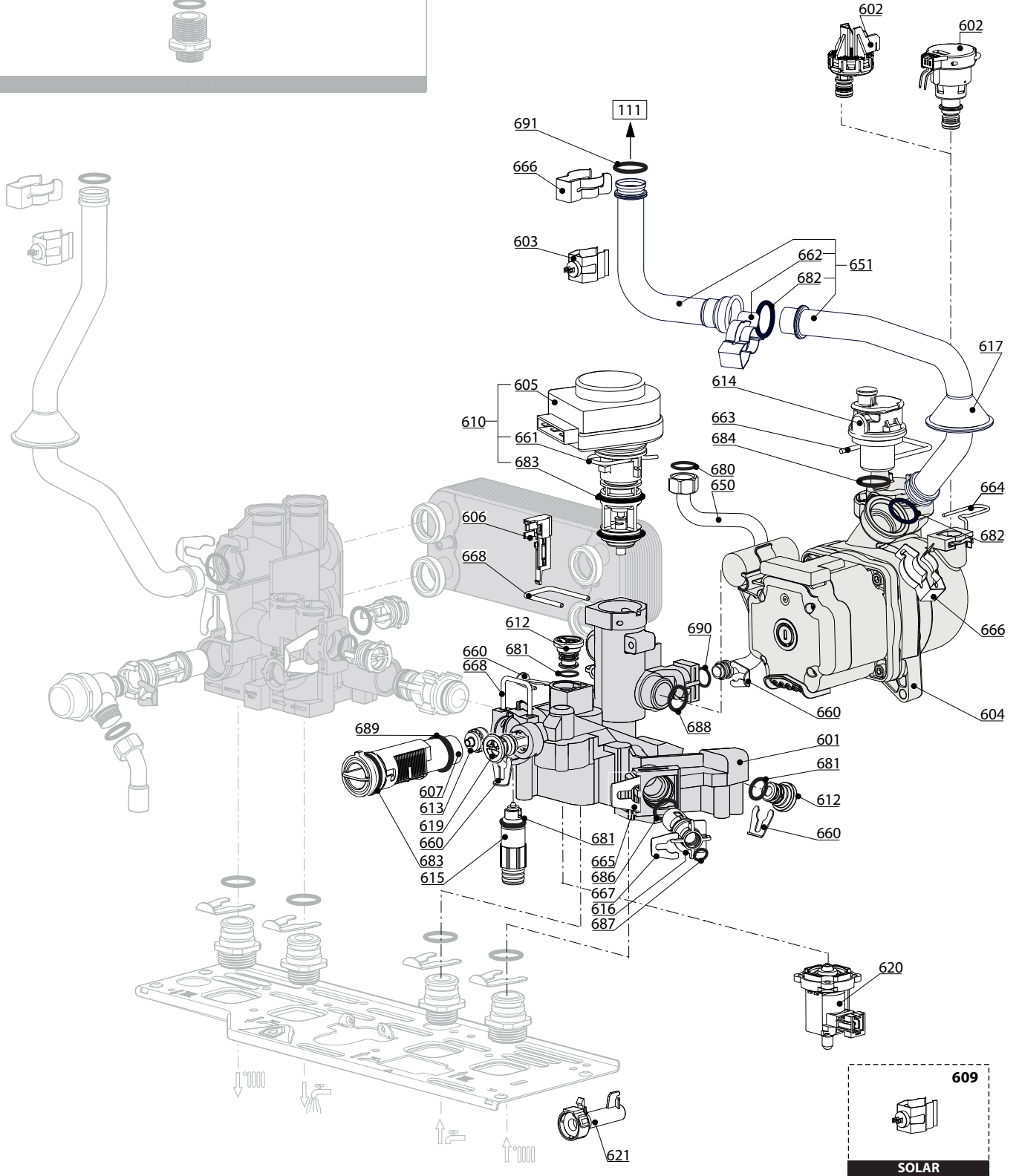
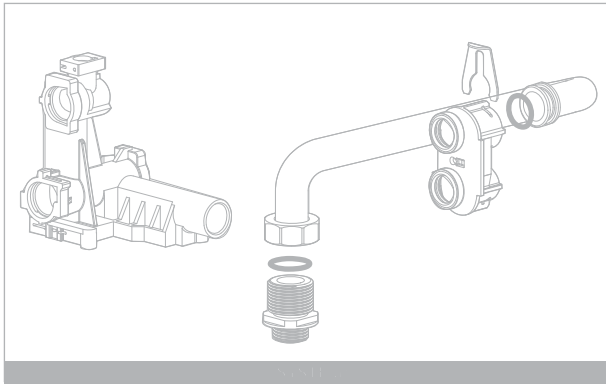

800

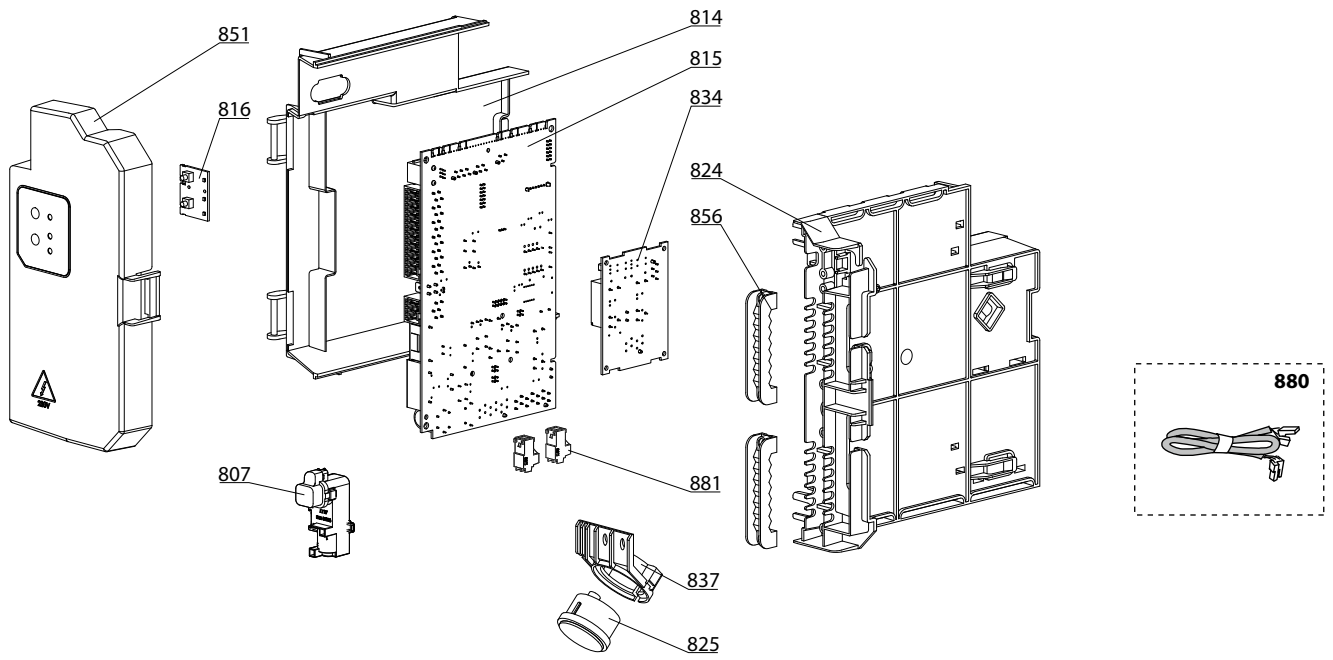

900

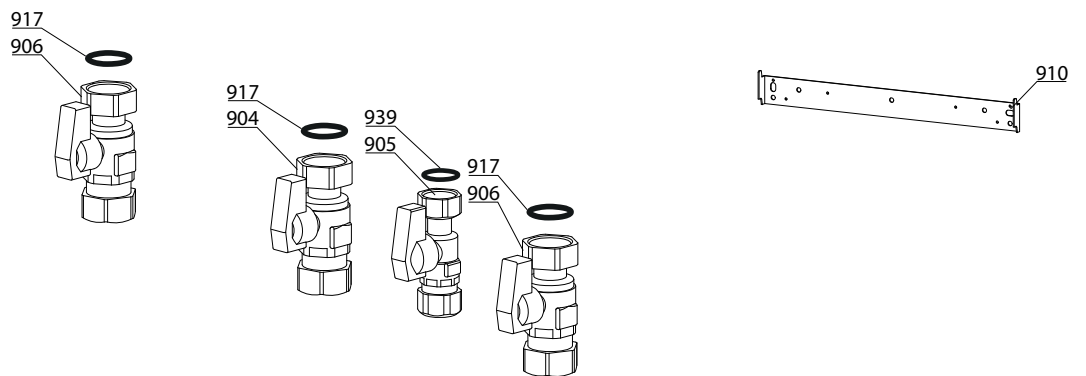

5000

5001
 Transf. gaz > GPL
 Conv. gas > GPL
 Trasn. gas > GPL
 Transf. gas > GPL

5002
 Transf. gaz > Nat
 Conv. gas > Nat
 Trasn. gas > Met
 Transf. gas > Met

5020
 Options
 Accessories
 Opzioni
 Accessorio

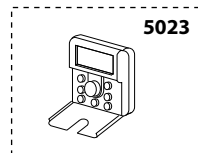
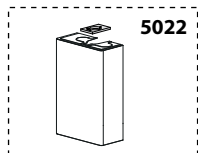
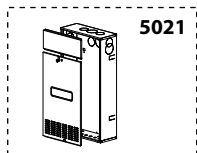

LIST OF THE ABBREVIATIONS

HW	: Hot water.
CW	: Cold water.
C	: Ceramic resistance (normal heating).
Ca	: Ceramic resistance (accelerated heating)
TP	: Immersion heater.
1F	: With fittings.
2F	: Without fittings.
3F	: With fittings and another outlet connection.
AMI	: With mixing valve.
SMI	: Without mixing valve.
PUISS	: Power of th appliance.
PN	: Appliance with normal pression.
LP	: Appliance with low pression.
PV	: Appliance with variable power.
PF	: Appliance with fixed power.

IDENTIFICATION PLATE

SERIAL NUMBER

10 Characters :	04 05 125 011	Sequential number
		Manufacturing day
		Year of manufacture
11 Characters :	1 95 065004 - 31	Technical number of the appliance
Month of manufacture :		Sequential number
from 1 to 9 → Jan. to Sep.,		Year of manufacture
O → Oct., N → Nov.,		
D → Dec.		
19 Characters :	08 05 0013199 900640031	Product reference
Year of manufacture		Sequential number
Month of manufacture		
20 Characters :	3675007 XX 2 07 070 00315	Sequential number
Product reference		Manufacturing day
Millenium of manufacture		Year of manufacture
21 Characters :	3675007 XX 07 070 0000315	Sequential number
Product reference		Manufacturing day
Year of manufacture		