



ARISTON

SPARE PARTS EXPLODED VIEW GAS-WALL BOILER ATM. BURNER

Model

BS II

R8203255-11 - 30/12/2015

BS II

Gas-wall boiler atm. burner

1	3300296	BS II 24 CF	10-2009	12-2011
1	3300438	BS II 24 CF NG	09-2011	-
2	3300808	BS II 24 CF NG EU		
3	3300419	BS II 15 FF	07-2011	12-2011
3	3300441	BS II 15 FF	09-2011	-
4	3300295	BS II 24 FF	10-2009	12-2011
4	3300415	BS II 24 FF LPG	03-2011	12-2011
4	3300439	BS II 24 FF NG	11-2011	-
4	3300440	BS II 24 FF LPG	11-2011	-
4	3300571	BS II 24 FF UZBEKISTAN	05-2013	-
Col	Reference	Model type	Begin	End

100
200
300
400

BS II

Gas-wall boiler atm. burner

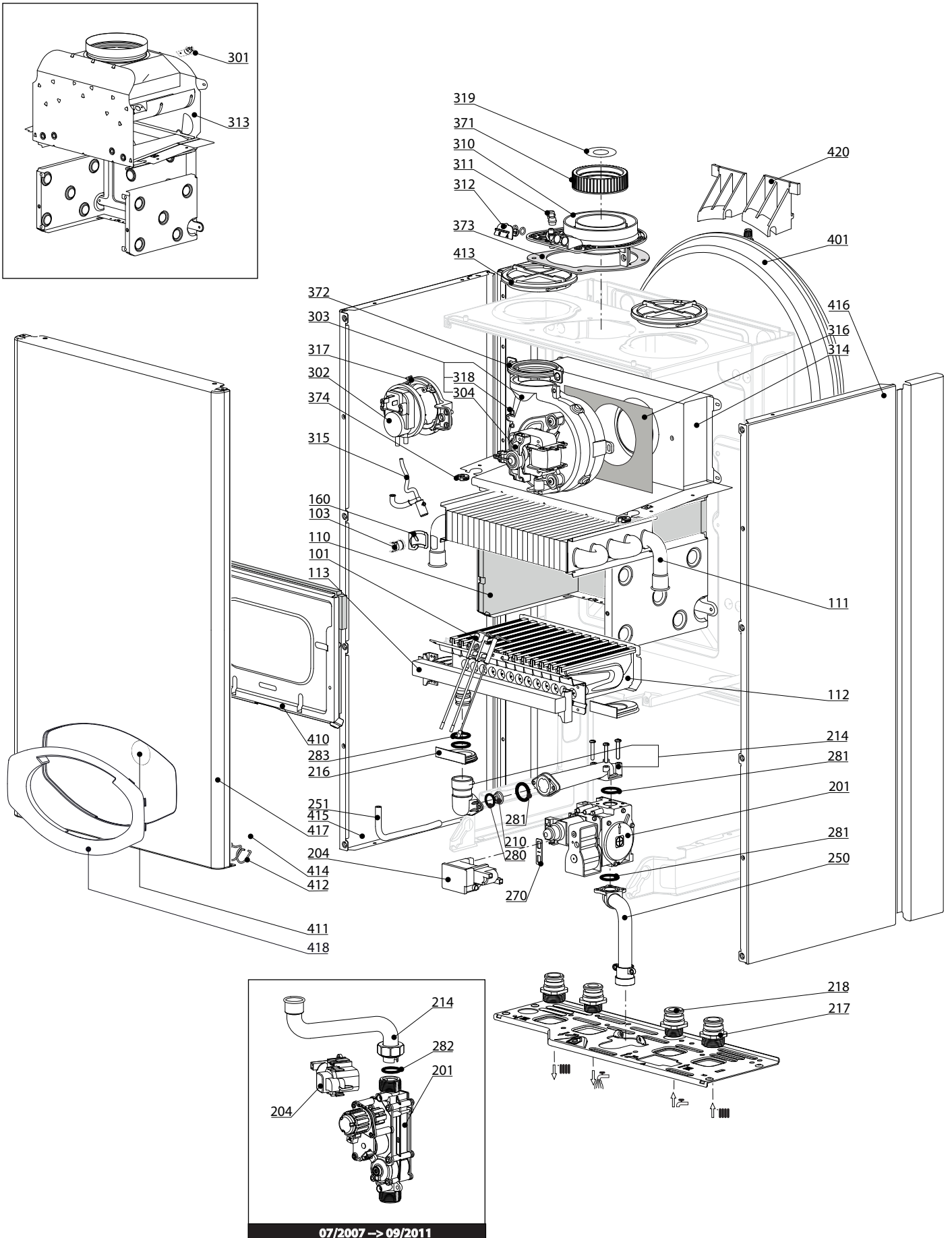

07/2007 -> 09/2011

R8208518

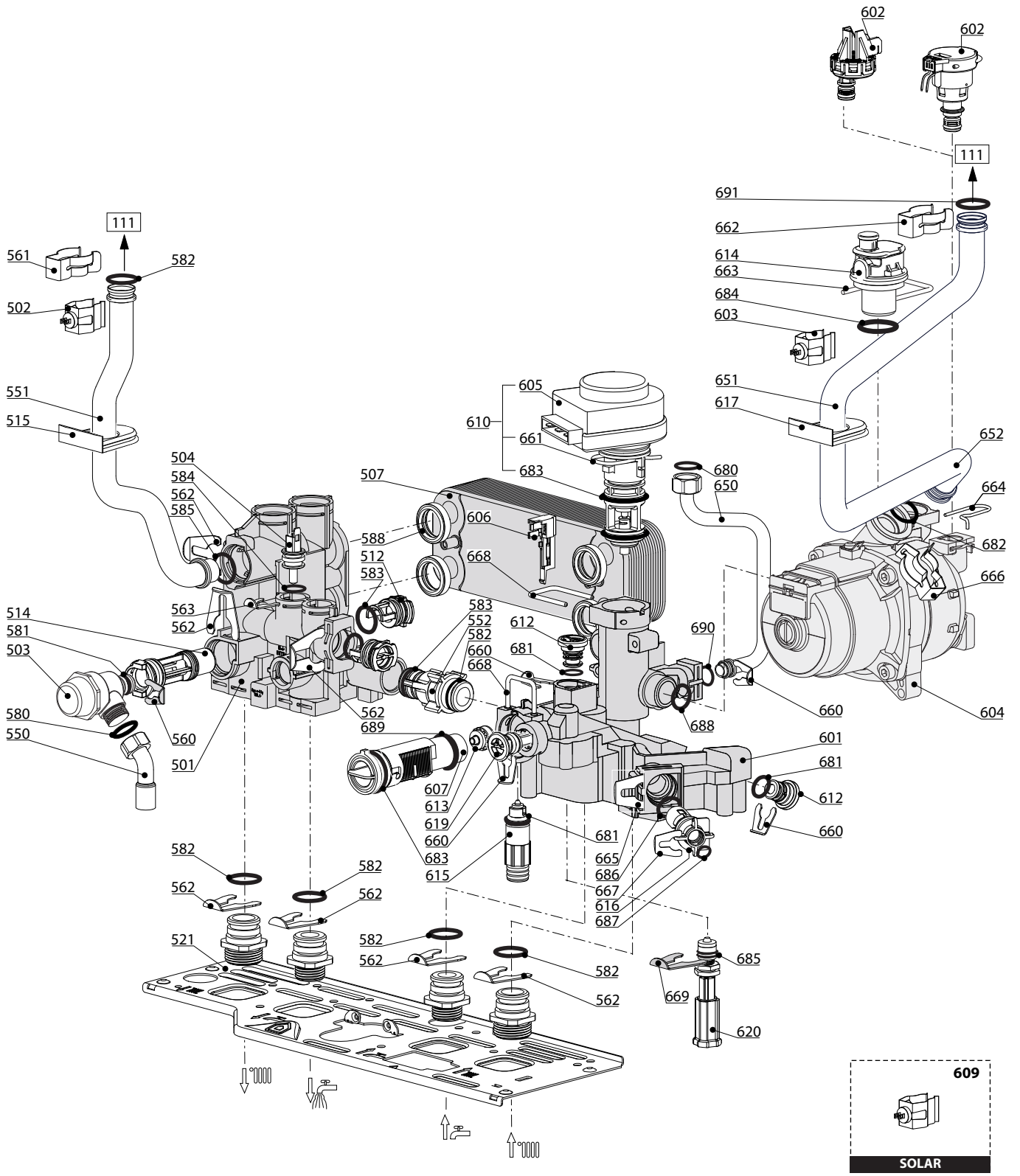

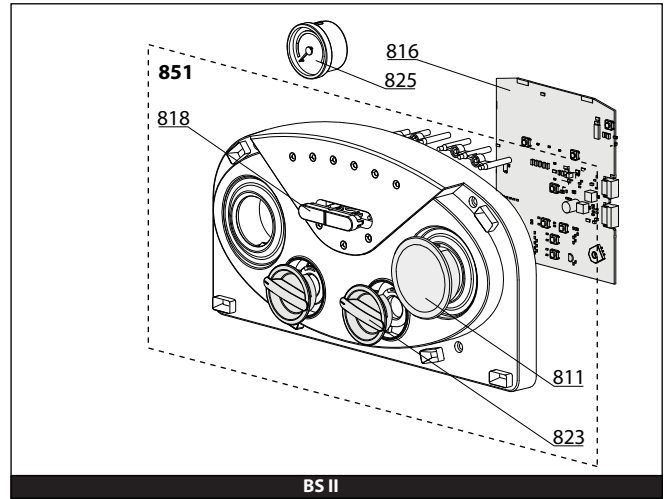
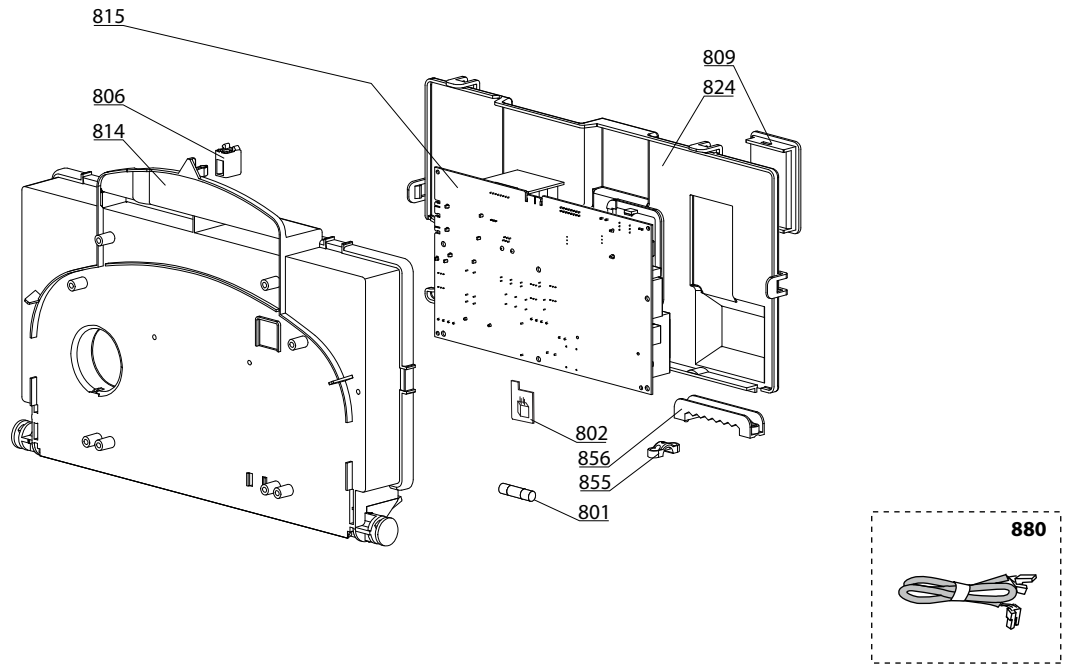

900

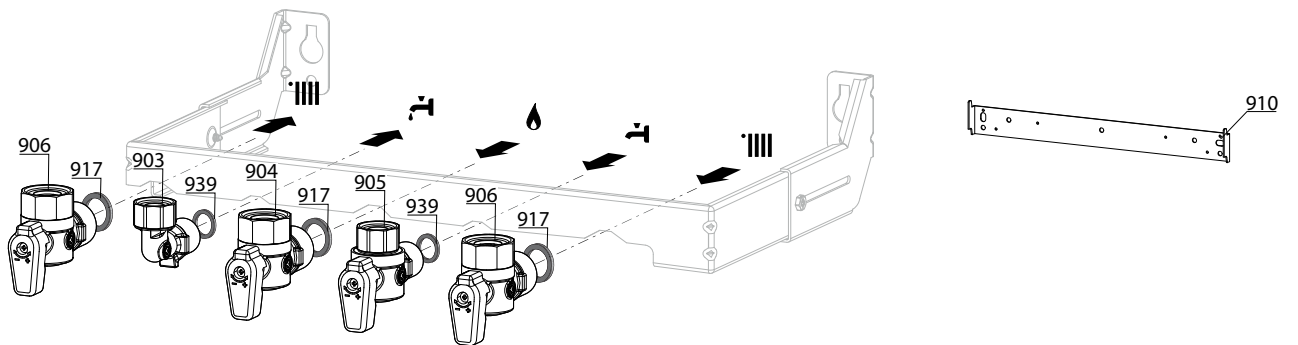

5000

- | | | |
|---|---|---|
| <p>5001
 Transf. gaz > GPL
 Conv. gas > GPL
 Trasn. gas > GPL
 Transf. gas > GPL</p> | <p>5002
 Transf. gaz > Nat
 Conv. gas > Nat
 Trasn. gas > Met
 Transf. gas > Met</p> | <p>5020
 Options
 Accessories
 Opzioni
 Accessorio</p> |
|---|---|---|

LIST OF THE ABBREVIATIONS

HW	: Hot water.
CW	: Cold water.
C	: Ceramic resistance (normal heating).
Ca	: Ceramic resistance (accelerated heating)
TP	: Immersion heater.
1F	: With fittings.
2F	: Without fittings.
3F	: With fittings and another outlet connection.
AMI	: With mixing valve.
SMI	: Without mixing valve.
PUISS	: Power of th appliance.
PN	: Appliance with normal pression.
LP	: Appliance with low pression.
PV	: Appliance with variable power.
PF	: Appliance with fixed power.

IDENTIFICATION PLATE

SERIAL NUMBER

10 Characters :	04 05 125 011		
		Sequential number	
		Manufacturing day	
		Year of manufacture	
11 Characters :	1 95 065004 - 31		
Month of manufacture :		Technical number of the appliance	
from 1 to 9 → Jan. to Sep.,		Sequential number	
O → Oct., N → Nov.,		Year of manufacture	
D → Dec.			
19 Characters :	08 05 0013199 900640031		
Year of manufacture		Product reference	
Month of manufacture		Sequential number	
20 Characters :	3675007 XX 2 07 070 00315		
Product reference		Sequential number	
Millenium of manufacture		Manufacturing day	
		Year of manufacture	
21 Characters :	3675007 XX 07 070 0000315		
Product reference		Sequential number	
Year of manufacture		Manufacturing day	